

ionian INN-N-SW

 Contemporary double-ended bath

- Made from QUARRYCAST®
 - One piece casting of rare volcanic limestone and resin
 - Harder & more durable than acrylic
- Easy clean high gloss finish
- Exterior can be painted
- 25 year guarantee

 Moderne symmetrische Badewanne

- Hergestellt aus QUARRYCAST®
 - Ein Gussteil aus seltenem vulkanischen Kalkstein und Harz
 - Härter und haltbarer als Acryl
- Leicht zu reinigende glänzende Oberfläche
- Außenseite überstreichbar
- 25 Jahre Garantie

 Baignoire moderne

- Fabriquée en QUARRYCAST®
 - Ensemble d'une pièce en pierre volcanique rare et résine
 - Matériau plus dur et plus résistant que l'acrylique
- Fini ultra brillant, facile à nettoyer
- L'extérieur peut être peint
- Garantie de 25 ans

 Bañera contemporánea

- Hecho de QUARRYCAST®
 - Hecho en una pieza de piedra volcánica y resina
 - Más resistente y duradero que acrílico
- Fácil de limpiar y acabado brillante
- El exterior se puede pintar
- 25 años de garantía

 Vasca contemporanea

- Costituito da QUARRYCAST®
 - Un unico pezzo di rara roccia calcarea vulcanica e resina
 - Più robusto e resistente dell'acrilico
- Intensa finitura lucida facile da pulire
- L'esterno può essere verniciato
- 25 anni di garanzia

Recommended: K12 / K17 / K40



K-12-PC K-12-BN
K-12-PB K-12-PN

K-17-PC K-17-BN
K-17-PB K-17-PN

K-40-PC
K-40-BN

PC Polished chrome, Chrom poliert, Chromé, Cromado brillante, Cromo metallico lucidato
PB Polished Brass, Messing poliert, Doré, Latón pulido, Ottone lucidato
BN Brushed nickel, Nickel gebürstet, Nickel mat, Niquel satinado, Nickel spazzolato
PN Polished nickel, Nickel poliert, Nickel brillant, Niquel brillante, Nickel lucidato

25
years

Qc® rich in
volcanic
limestone

UPC
C Massachusetts Code:
File No. Pending
cUPC listing by IAPMO:
File No. Pending



ionian INN-N-SW

Top view

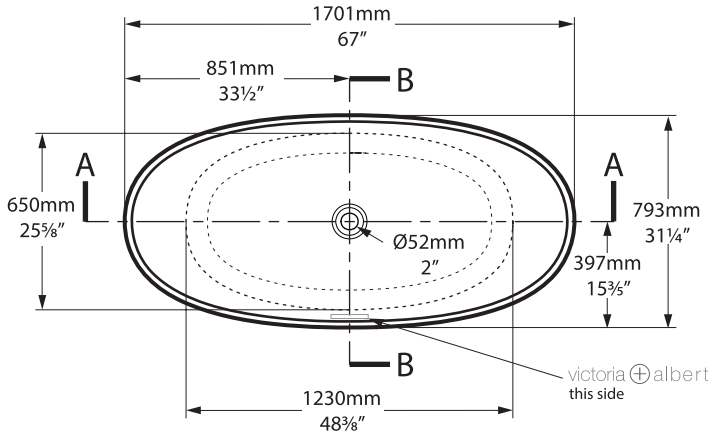

Front view

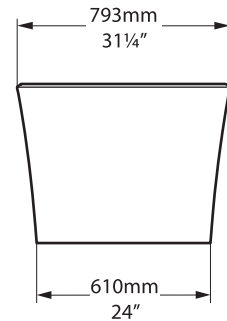

Side view

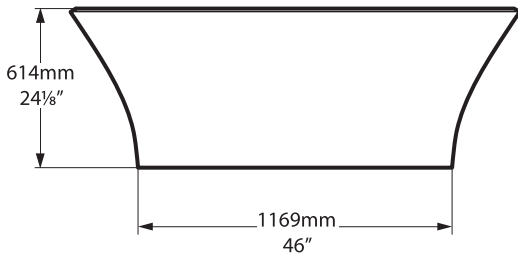

Section BB

Shown with K17 waste kit

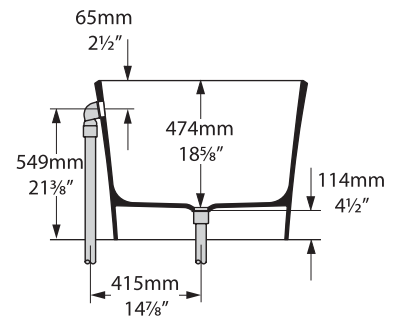

Section AA

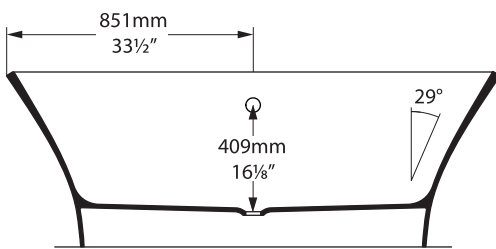

Section BB

Shown with K12/K40 waste kit

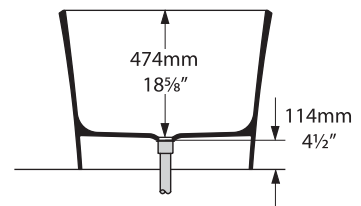

*All measurements subject to +/-5% tolerance
*Overflow hole not drilled

